

Chain-O-Flex Overhead Conveyors

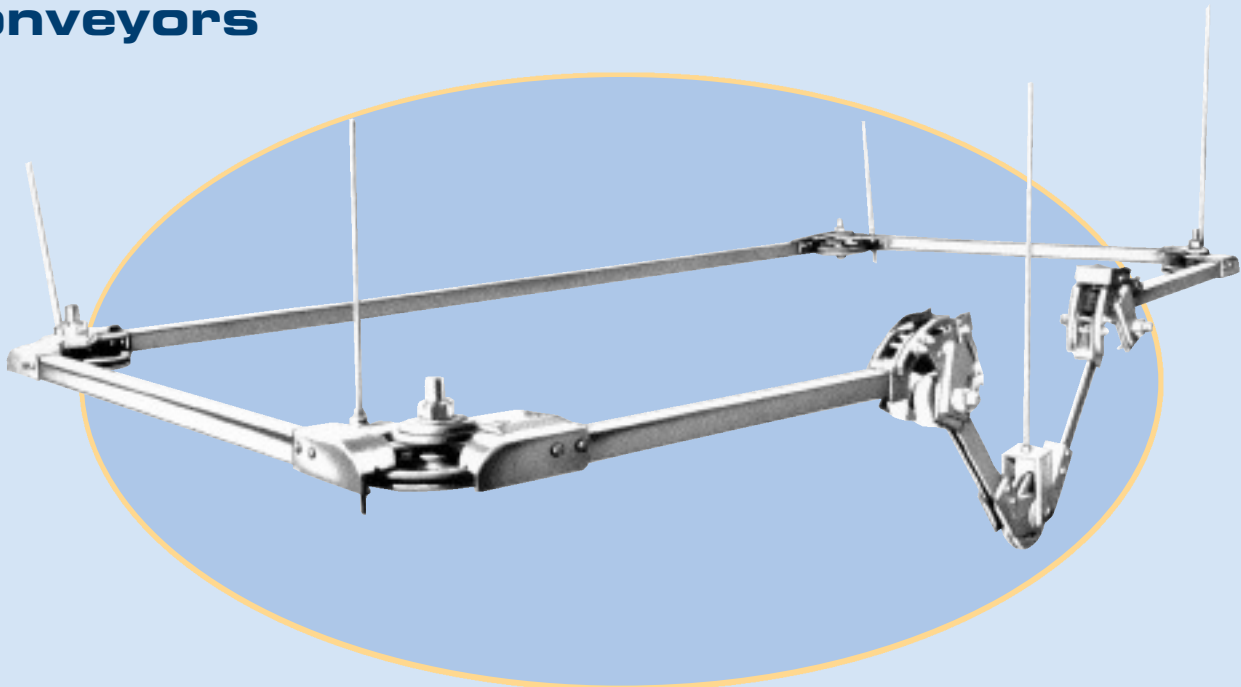

Modular • Bolted Construction • Do-It-Yourself • Floor Or Ceiling Mounted

The modular construction of the COF Series is a must for any progressive company. This unique construction allows for easy modification due to growth or product change, etc. This overhead conveyor is offered in standard lengths of 10 feet, but can be modified to any other size. These units can be suspended from the ceiling or are self-standing.

The fact that it has fewer moving parts lends itself to long life and virtually maintenance-free operation. This design works well in high heat conditions, such as powder or other paint applications. In excessive heat special bearings are available.

We also offer a multi-level installation. Other features include vertical dip hardware which allows for assembly, cleaning, and painting at various elevations. It has unlimited applications. If you have a particular requirement that does not lend itself to our standard system, consult factory for engineering assistance.

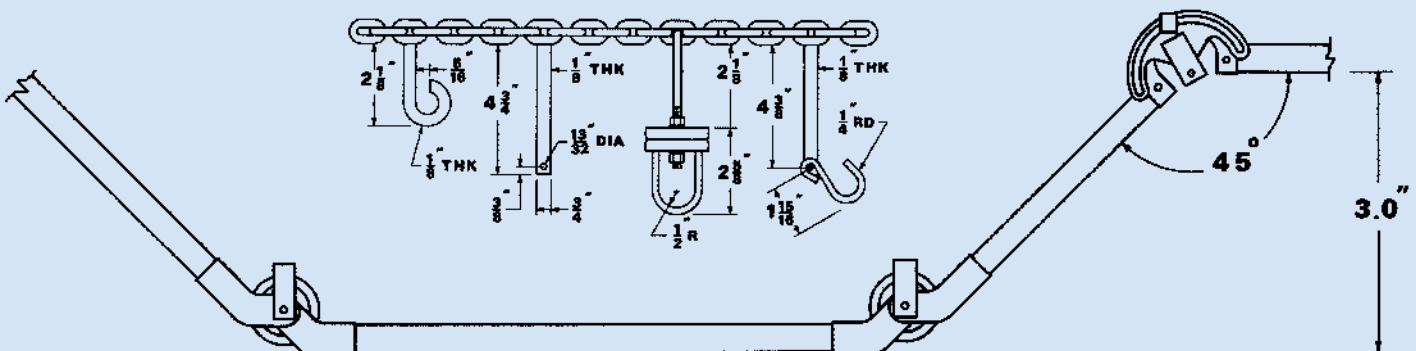

Chain-O-Flex Components

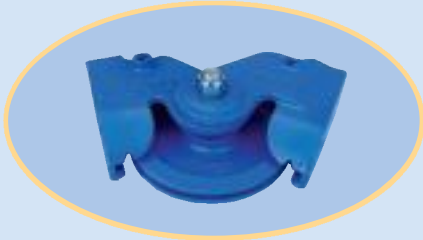

HORIZONTAL CORNER/MODEL 570:
The horizontal corners adjust from 20° to 180° which allows flexibility for your individual system.



OILER WITH HANGER/MODEL 540:
Pulsating oiler automatically lubricates chain.



TOP VERTICAL CORNER/MODEL 550:
This corner adjusts from 0° to 180° and is used when a change in elevation is required such as a dipping application.

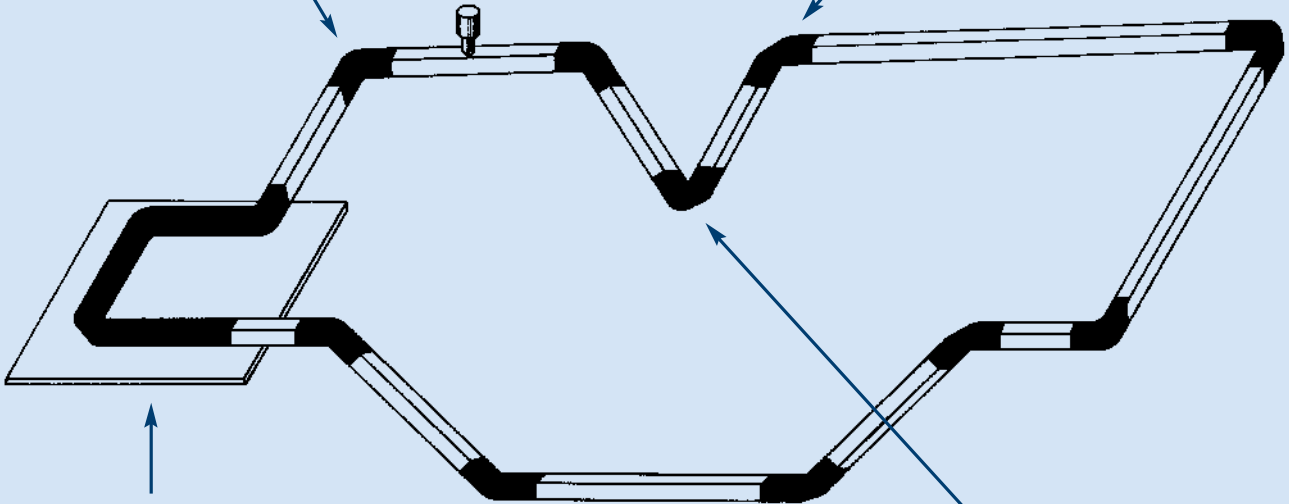

DRIVE UNIT/MODEL 5360: This standard universal drive unit comes with a 1 HP motor and a variable speed range from 4 to 12 FPM. Specialty voltage.



BOTTOM VERTICAL CORNER/MODEL 560: Bottom vertical also adjusts from 0° to 180°. Used to return product to higher level.

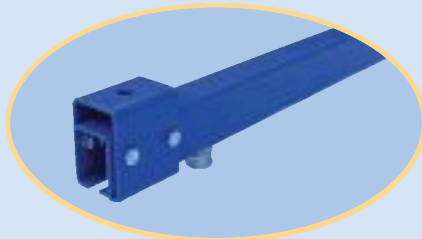

TRACK/MODEL 520: This 10 ga. heavy duty straight track is standard in 10 ft. lengths. Track length can be shortened to fit your exact requirements.