

Slider Bed Conveyors

Powered conveyors for an unlimited variety of products; small parts, containers or cartons. Used in packaging, shipping and assembly. An economical method of moving medium weight products.

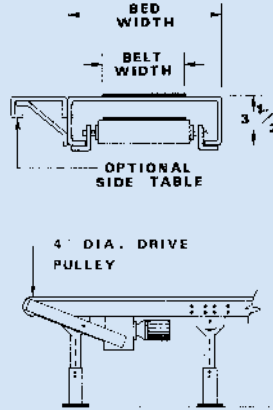

SB SERIES SPECIFICATIONS:

1/2 HP 220/3/60 Motor ♦ 12 Ga. Formed Bed 3-1/2" Deep ♦ Black PVC Belt ♦ 60 FPM Standard ♦ 4" Drive Pulley ♦ Capacity: 300-900 lbs.

For electrical controls see page 21.

► SB SERIES

Model No	Belt Width In	Bed Width In	WEIGHT					
			Over-All Length: 5 Ft	Over-All Length: 10 Ft	Over-All Length: 15 Ft	Over-All Length: 20 Ft	Over-All Length: 25 Ft	Over-All Length: 30 Ft
SB-12	12	16	261	305	370	413	478	523
SB-16	16	20	292	355	442	505	592	655
SB-18	18	22	301	368	462	529	623	690
SB-20	20	24	332	386	483	553	650	720
SB-24	24	28	354	412	518	596	700	778
SB-30	30	34	380	450	560	640	760	830

Roller Bed Conveyors

This horizontal belt over roller conveyor has been designed to move products and materials from one department to the other. Each roller helps minimize belt friction, thus providing for greater capacities.

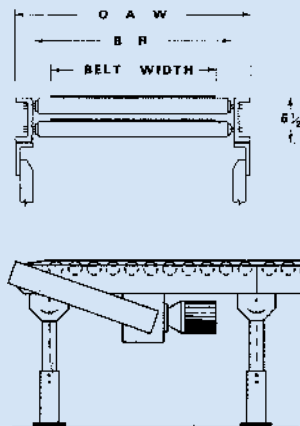

RB SERIES SPECIFICATIONS:

1/2 HP 220/3/60 Motor ♦ 1.9" 16 Ga. Rollers on 3" to 6" Centers ♦ 5-1/2" 10 Ga. Channel ♦ PVC Belt ♦ 60 FPM ♦ 4" Drive Pulley ♦ Capacity: 1000 lbs.

For electrical controls see page 21.

► RB SERIES

Model No	Belt Width In	Over-All Width In	WEIGHT					
			Over-All Length: 5 Ft	Over-All Length: 10 Ft	Over-All Length: 15 Ft	Over-All Length: 20 Ft	Over-All Length: 25 Ft	Over-All Length: 30 Ft
RB-12	12	18	250	325	405	490	569	625
RB-16	16	22	275	358	443	530	615	698
RB-18	18	24	288	378	468	558	648	738
RB-20	20	26	300	394	488	582	676	770
RB-24	24	30	323	428	533	638	743	848